

CAD FILE:

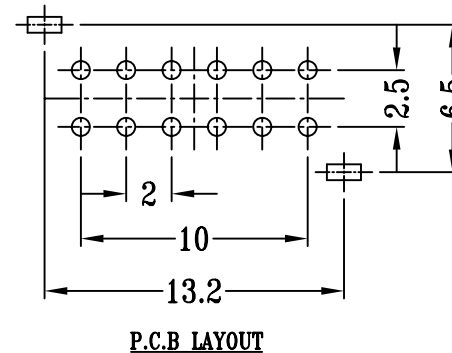
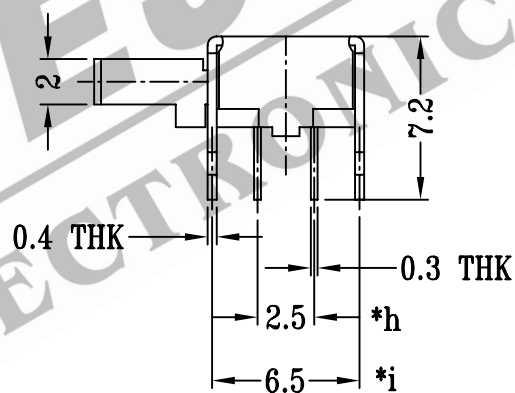
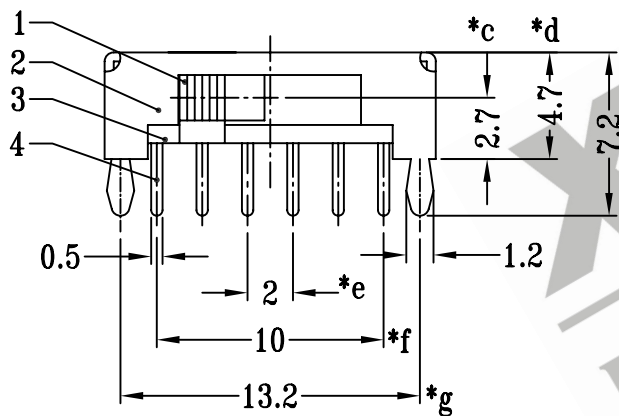
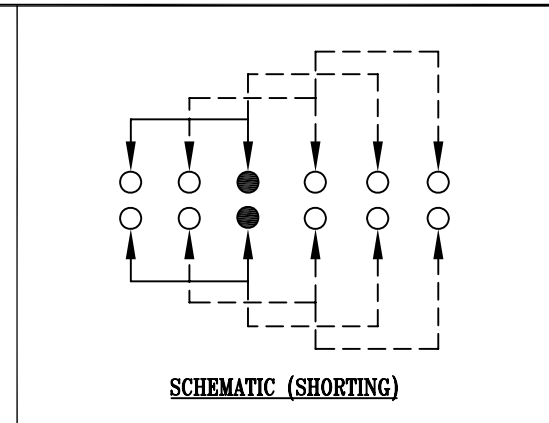
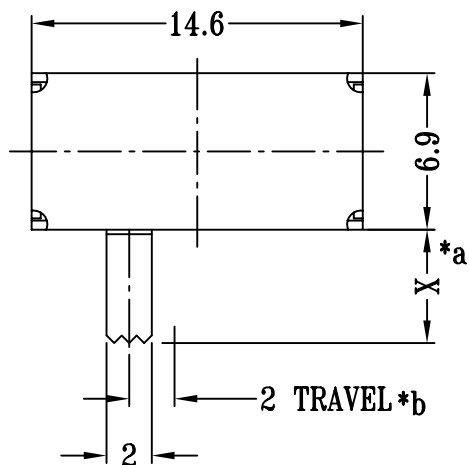

注:带"*"表示关键尺寸(9个)

NO.	PARTS	MATERIALS	Q'TY	FINISH	TOLERANCE UNLESS SPECIFIED	SHENZHEN XIEJIA ELECTRONICS CO.,LTD.				
8										
7										
6	SPRING PLATE	STAINLESS STEEL	1	NATURAL	WITHIN: 1.5±0.1mm	ISSUE	DATE	DESCRIPTIONS OF REVISION		APPD.
5	CONTACT CLIP	PBS	2	Ag CLAD	OVER: 1.5±0.2mm					
4	TERMINAL	BRASS STRIP	12	Ag PLATED OVER Ni PLATED	TITLE : HORIZONTAL SLIDE SWITCH	UNIT : mm	DRWG NO.:XJ-DR-SK24D22-00			
3	BASE	PHENOLIC RESIN	1	NATURAL	MODEL: SK-24D22	SCALE: 3:1	DWN.	ZHOUYU	2006-10-9	
2	FRAME	STEEL STRIP	1	Ni PLATED			CHK'D	FANGYING	2006-10-9	
1	KNOB	POM	1	BLACK	ALL MATERIALS MUST BE COMPLIANT TO ROHS		APPD.	KANGXINAN	2006-10-9	